

2FT With Motion Sensor LED Linear High Bay

- ◆ Design with a motion sensor, which can be easily removed as well. Also we can provide a multifunction remote separately to change any settings as you need.
- ◆ Unique grille reflective cup lampshade design With Motion Sensor makes the glow more focus, anti-glare, UGR<19.
- ◆ Direct luminescence with reflective cup, provide higher luminous efficiency up to 120lm/W.
- ◆ Adopt a high quality, well-known brand of driver that can handle AC100-277V, making it highly suitable for commercial lighting.
- ◆ Suspended mount and surface mount are available.

Part No.	Wattage
YRLHB-1501X21XX-005P	150W

Photometric

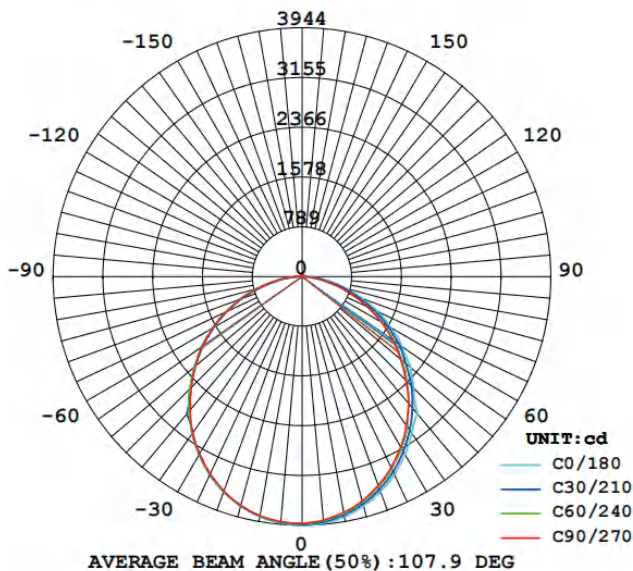

Height	AVR E	CENTER E	Diameter
2.00m	328.681x	985.961x	532.08cm
4.00m	82.171x	246.491x	1064.15cm
6.00m	36.521x	109.551x	1596.23cm
8.00m	20.541x	61.621x	2128.31cm
10.00m	13.151x	39.441x	2660.38cm

Angle: 106.1deg

CERTIFICATIONS

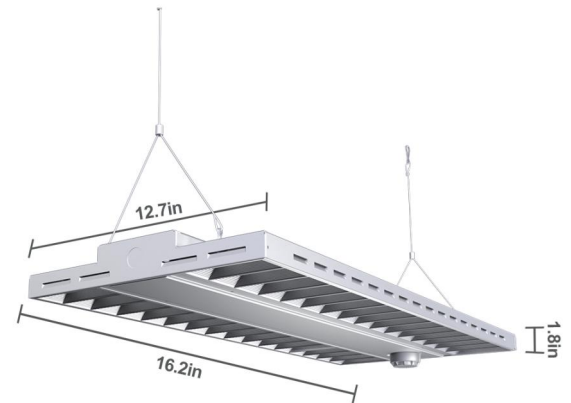

SPECIFICATIONS

Input Voltage	100-277Vac
Wattage	150W
Input Currents	1.30A
Power Factor	0.950

LIGHTING PERFORMANCE

Lumens	18000lm
Equivalency	2700W (Incandescent bulb)
CCT	5000K
Color Rendering Index (CRI)	90
Beam Angle	120°
Sensor mode	Microwave Induction
Control mode	Remote Control (optional)
Efficiency (lm/w)	≥120
Input Frequency	50/60Hz

Microwave Sensor-Factory Default

Detection area	100%
Hold Time	1min
Waiting time	10S
Preset brightness	20%
Light Sensitivity	150Lux

ENVIRONMENT

Operating Temperature	4°F to 104°F
Recommend Installation Height	20-26FT (6-8M)
Usage	Indoor

CONSTRUCTION

Housing	PE+PC
Colour	Black / White
Installation	Suspended / Surface Mount
Weight	-

LIFESPAN

Average Life (Hours)	50,000+
Warranty	5 years

4FT With Motion Sensor LED Linear High Bay

- ◆ Design with a motion sensor, which can be easily removed as well. Also we can provide a multifunction remote separately to change any settings as you need.
- ◆ Unique grille reflective cup lampshade design With Motion Sensor makes the glow more focus, anti-glare, UGR<19.
- ◆ Direct luminescence with reflective cup, provide higher luminous efficiency up to 120lm/W.
- ◆ Adopt a high quality, well-known brand of driver that can handle AC100-277V, making it highly suitable for commercial lighting.
- ◆ Suspended mount and surface mount are available.

Part No.	Wattage
YRLHB-2001X41XX-005P	200W

Photometric

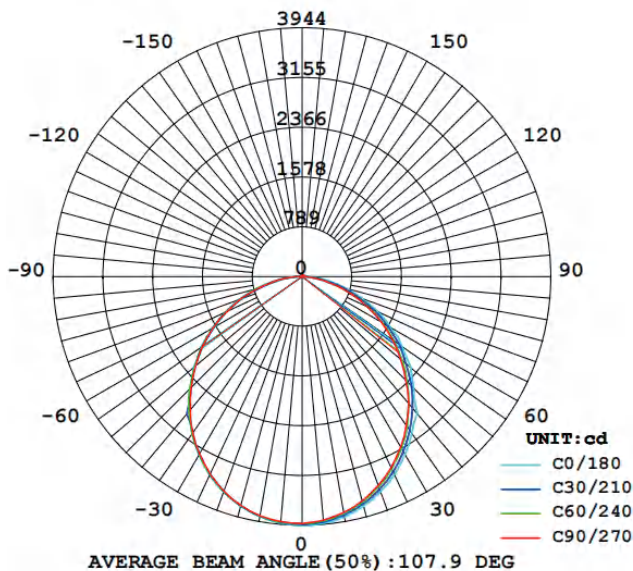

Height	AVR E	CENTER E	Diameter
2.00m	328.681x	985.961x	532.08cm
4.00m	82.171x	246.491x	1064.15cm
6.00m	36.521x	109.551x	1596.23cm
8.00m	20.541x	61.621x	2128.31cm
10.00m	13.151x	39.441x	2660.38cm

Angle: 106.1deg

CERTIFICATIONS

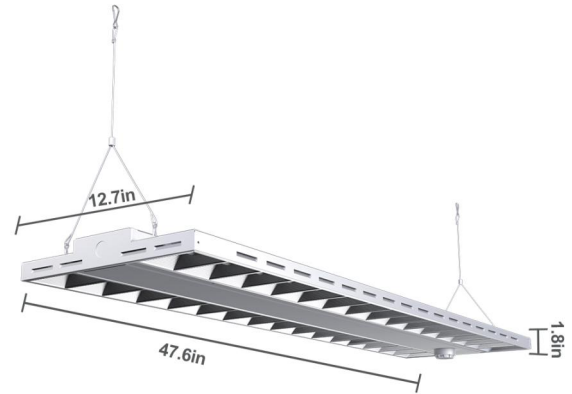

SPECIFICATIONS

Input Voltage	100-277Vac
Wattage	200W
Input Currents	1.70A
Power Factor	0.950

LIGHTING PERFORMANCE

Lumens	24000lm
Equivalency	3600W (Incandescent bulb)
CCT	5000K
Color Rendering Index (CRI)	90
Beam Angle	120°
Sensor mode	Microwave Induction
Control mode	Remote Control (optional)
Efficiency (lm/w)	≥120
Input Frequency	50/60Hz

Microwave Sensor-Factory Default

Detection area	100%
Hold Time	1min
Waiting time	10S
Preset brightness	20%
Light Sensitivity	150Lux

ENVIRONMENT

Operating Temperature	4°F to 104°F
Recommend Installation Height	20-26FT (6-8M)
Usage	Indoor

CONSTRUCTION

Housing	PE+PC
Colour	Black / White
Installation	Suspended / Surface Mount
Weight	-

LIFESPAN

Average Life (Hours)	50,000+
Warranty	5 years

2FT LED Linear High Bay

- ◆ Unique grille reflective cup lampshade design makes the glow more focus, anti-glare, UGR<19.
- ◆ Direct luminescence with reflective cup, provide higher luminous efficiency up to 120lm/W.
- ◆ Adopt a high quality, well-known brand of driver that can handle AC100-277V, making it highly suitable for commercial lighting.
- ◆ Suspended mount and surface mount are available.

Part No.

Wattage

YRLHB-1501X21XX-006

150W

Photometric

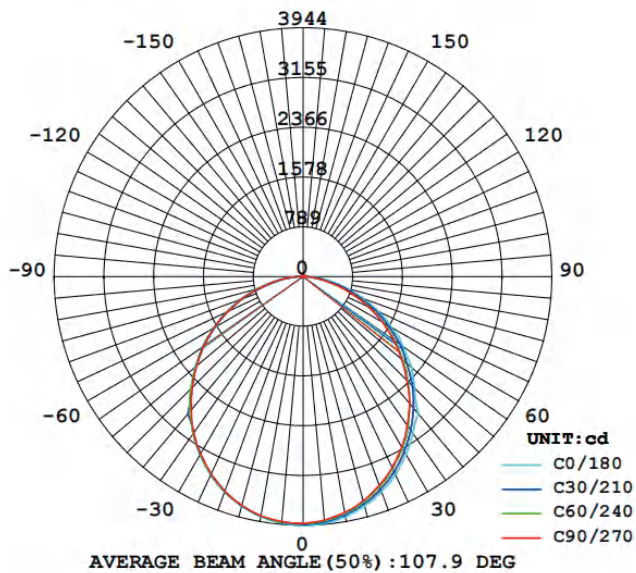

Height	AVR E	CENTER E	Diameter
2.00m	328.68lx	985.96lx	532.08cm
4.00m	82.17lx	246.49lx	1064.15cm
6.00m	36.52lx	109.55lx	1596.23cm
8.00m	20.54lx	61.62lx	2128.31cm
10.00m	13.15lx	39.44lx	2660.38cm

Angle: 106.1deg

CERTIFICATIONS

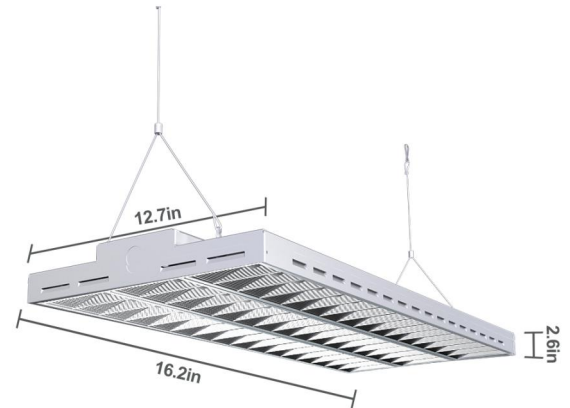

SPECIFICATIONS

Input Voltage	100-277Vac
Wattage	150W
Input Currents	1.30A
Power Factor	0.950

LIGHTING PERFORMANCE

Lumens	18000lm
Equivalency	2700W (Incandescent bulb)
CCT	5000K
Color Rendering Index (CRI)	90
Beam Angle	120°
Efficiency (lm/w)	≥120
Input Frequency	50/60Hz

ENVIRONMENT

Operating Temperature	4°F to 104°F
Recommend Installation Height	20-26FT (6-8M)
Usage	Indoor

CONSTRUCTION

Housing	PE+PC
Colour	Black / White
Installation	Suspended / Surface Mount
Weight	-

LIFESPAN

Average Life (Hours)	50,000+
Warranty	5 years

4FT LED Linear High Bay

- ◆ Unique grille reflective cup lampshade design makes the glow more focus, anti-glare, UGR<19.
- ◆ Direct luminescence with reflective cup, provide higher luminous efficiency up to 120lm/W.
- ◆ Adopt a high quality, well-known brand of driver that can handle AC100-277V, making it highly suitable for commercial lighting.
- ◆ Suspended mount and surface mount are available.

Part No.

Wattage

YRLHB-2001X41XX-006

200W

Photometric

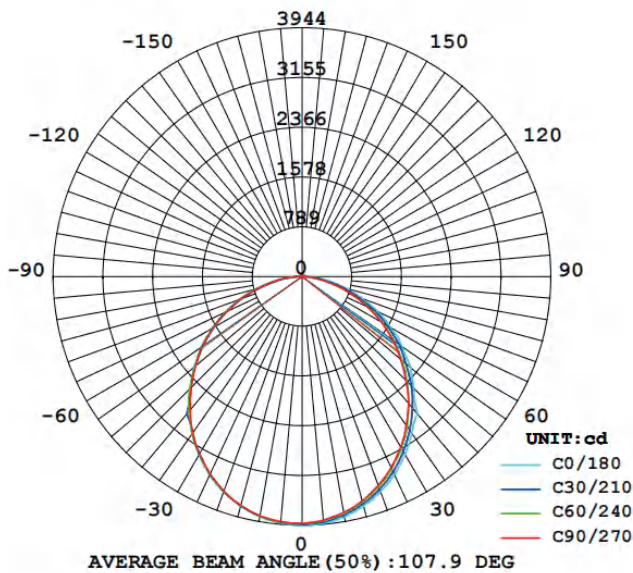

Height	AVR E	CENTER E	Diameter
2.00m	328.681x	985.961x	532.08cm
4.00m	82.171x	246.491x	1064.15cm
6.00m	36.521x	109.551x	1596.23cm
8.00m	20.541x	61.621x	2128.31cm
10.00m	13.151x	39.441x	2660.38cm

Angle: 106.1deg

CERTIFICATIONS

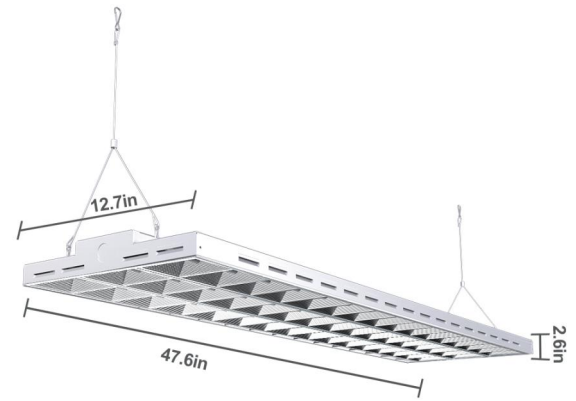

SPECIFICATIONS

Input Voltage	100-277Vac
Wattage	200W
Input Currents	1.70A
Power Factor	0.950

LIGHTING PERFORMANCE

Lumens	24000lm
Equivalency	3600W (Incandescent bulb)
CCT	5000K
Color Rendering Index (CRI)	90
Beam Angle	120°
Efficiency (lm/w)	≥120
Input Frequency	50/60Hz

ENVIRONMENT

Operating Temperature	4°F to 104°F
Recommend Installation Height	20-26FT (6-8M)
Usage	Indoor

CONSTRUCTION

Housing	PE+PC
Colour	Black / White
Installation Type	Suspended / Surface Mount
Weight	-

LIFESPAN

Average Life (Hours)	50,000+
Warranty	5 years